



16726 146th St. SE Suite 135  
Monroe, WA 98272  
Phone 877-851-4491

# Installation Guide

## Contents

**Plan the installation**

**Rough In**

**Determine Valve Height**

**Rough In Kit**

**New Construction**

**Pipe runs**

**Low voltage wire**

**Test the system**

**Typical Pipe Runs Diagram**

**Trim**

**Trim Kit**

**Retro fit an existing home**

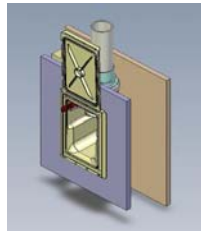

**Important** - The maximum wall thickness the valve can work with is 3/4 inch.

### **Warning**

*This Manual assumes that the installer has working knowledge and experience installing traditional Central Vacuum Systems.*

*It is critical that only parts supplied by Hide A Hose Inc. be used in the installation.*

*Parts include screws, seals, washers, hoses, sweep 90's, 45's, etc.*

*Failure to use these parts will void any warranty offered by the manufacture.*

*Installers are responsible for adhering to all local building codes.*

### **Plan the installation**

Planning is the key to the successful installation of a central vacuum system. A balance between the best locations for the inlet valves and the practicality of installing in these locations must be obtained. With a little ingenuity most locations can be reached.

#### **Hose lengths**

Let the customer know that you will custom size the hose to fit each floor. Hose kits come in 30', 40', or 50' lengths.

#### **Power Unit Selection**

It is important to keep in mind that air flow is reduced with longer hoses. To compensate for the loss of air flow a larger power unit is required.

#### **Valve locations**

A 50' hose will usually cover between 1800-2300 sq. ft. Placement of the inlets should, if possible, be located in a hallway or in other areas that do not have high visibility

#### **Plan pipe runs**

Carefully read the section in this guide on "pipe runs". There is also a diagram of four typical pipe runs.

# Rough In

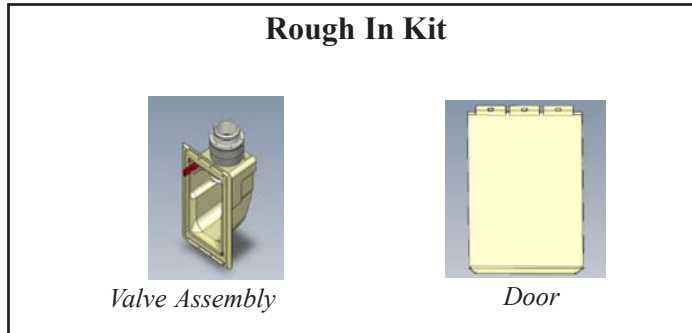

## Determine Valve Height

In a **down orientation** (tubing is being run in the crawl space ), align the bottom of the valve with the height of the electrical plug outlets (about 11 inches). Mounting the valve higher in a down orientation creates a more difficult angle for the hose to retract.

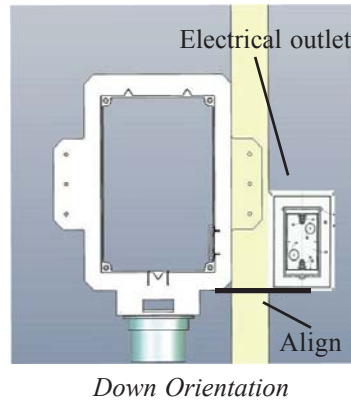

In an **up orientation** (hose exiting the valve towards the ceiling) most people find it more convenient with the valve mounted the height of the light switch outlets.

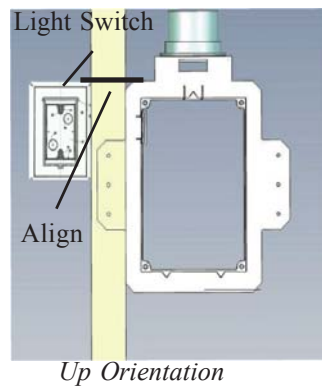

# New Construction

Attach the frame to the stud. Be sure the frame is level.

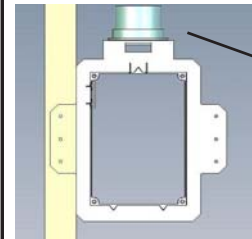
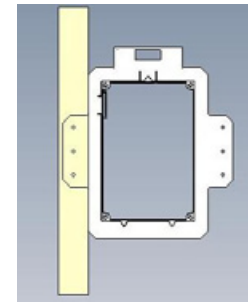

Insert the Pipe Fitting.

The Pipe Fitting is designed to slide in the frame to adjust for variations in wall board thickness.

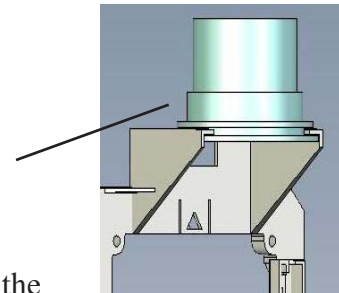

The maximum wall thickness the valve can work with is 3/4 inch.

Install the pipe into the fitting. Glue the pipe into the fitting, making sure it seats all the way to the ridge of the pipe fitting.

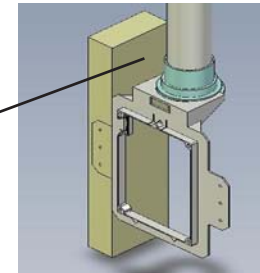

Install the mud cover

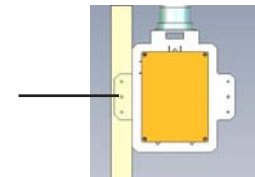

### Pipe runs

Refer to the diagram on the next page.

Unlike a traditional install, do not join pipe runs until you have enough pipe length to hold the hose. For example, if using a 40' hose install at least 44' of pipe before connecting to another pipe run.

In order to ensure enough pipe to store the hose, the pipe runs will sometimes need to begin running away from the power unit, then make a loop and head back to the power unit.

Any burr or excess glue glob can snag and damage the hose sock as it travels through the tubing. To prevent this be sure to always glue the pipe and not the fittings. Make sure to remove all burrs from the pipe ends that were cut. Carefully inspect the pipe to make sure the inside is smooth and that the pipe is round and undamaged.

Only Hide A Hose special sweep 90's, 45's and 22.5's can be in the section of pipe that stores the hose.



A 90 to a 22.5 is often needed to get around an obstacle.



Try to space out 90's as much as possible.

The more 90's used the more force is needed to pull the hose out of the wall. Try not to use more than 4 90's for each valve.

Try to avoid back to back 90's if at all possible.

It is important to design the pipe runs so the hose is stored on one plane.

Hose stored on two different planes.

### Low voltage wire

Run low voltage wire to each inlet just as you would with a standard central vacuum install.

### Test the system

It is a good idea to test the system by retracting a hose before the walls are sheet rocked.

Since the doors are needed to seal the system a hand ball can be placed over each valve opening that is not being tested to seal the system. In an up orination you will need to tape the hand ball in place.

Using a portable source of vacuum, check the system for sealed vacuum. Sealed vacuum at the valve should not vary more than three to five inches from the sealed vacuum at the power unit.

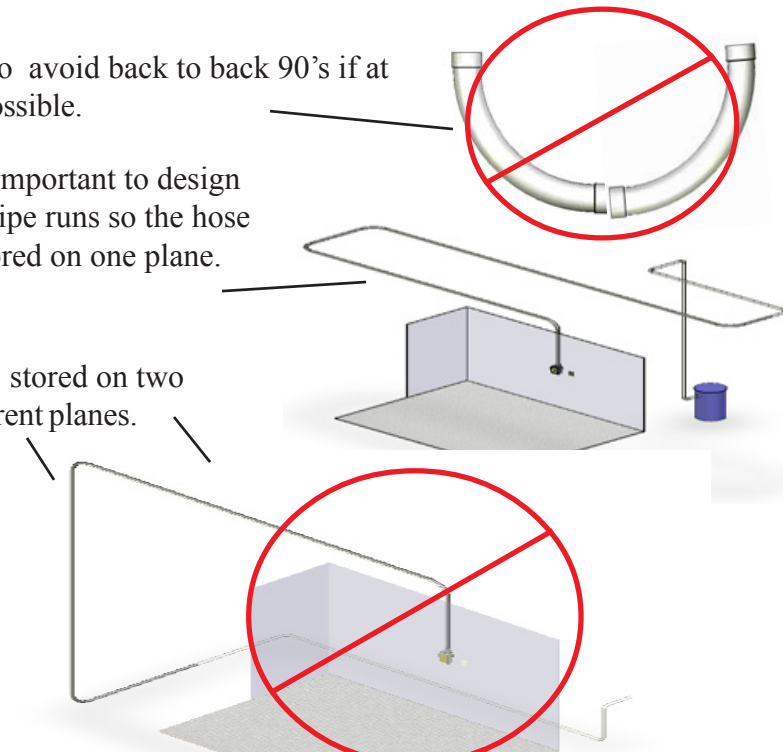

**Down Orientation**

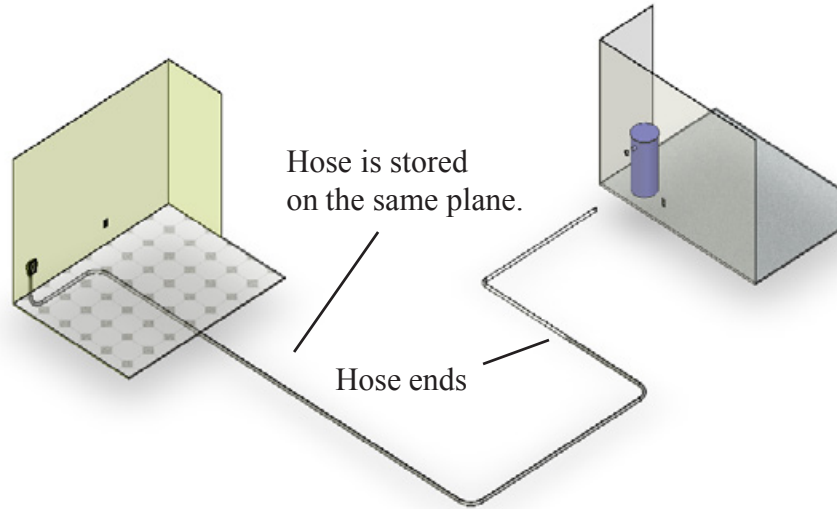

**Down two floors**

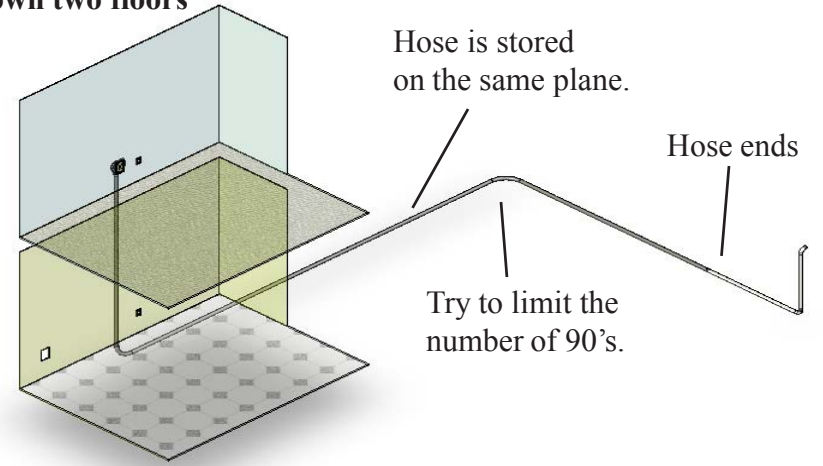

**Up Orientation**

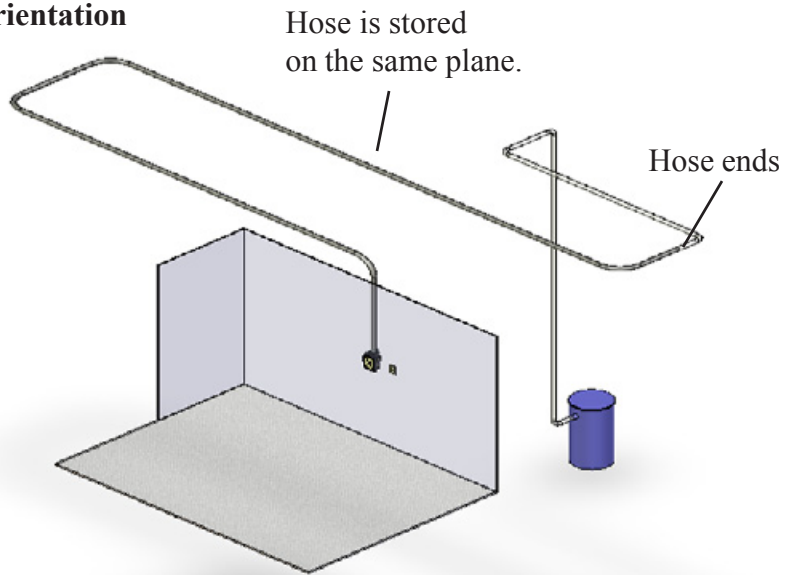

**Up two floors**

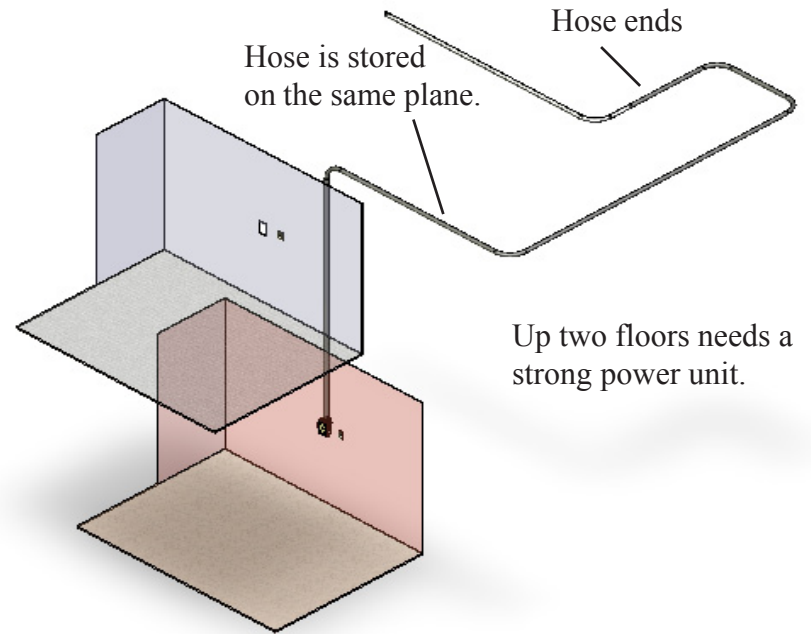

**Typical Pipe Runs Diagram**

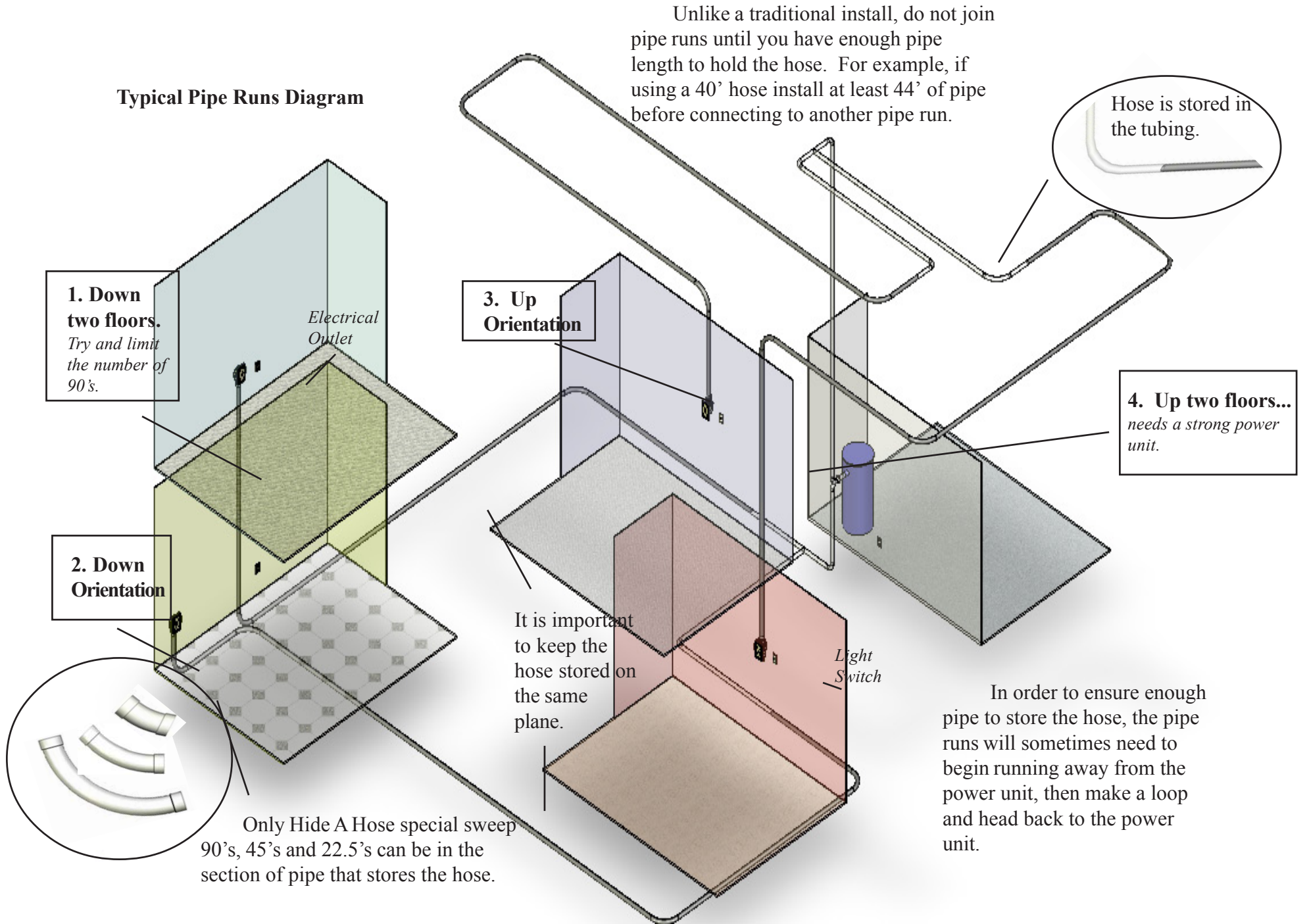

# Trim

## Trim Kit

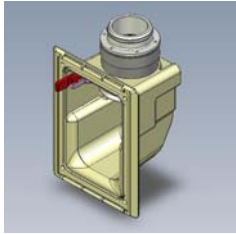

Valve assembly

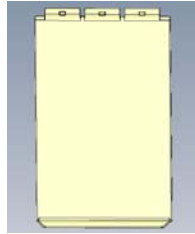

Door

The pointed tabs are used to secure the frame to the sheetrock while you install the valve. With new construction it is likely that these tabs were cut off by the sheet rock installers.

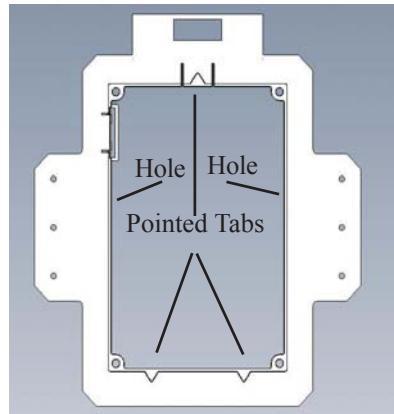

It might be helpful to push small finish nails horizontally into the sheet rock through the holes in the side of the frame.

Apply a lubricant to the o-ring.

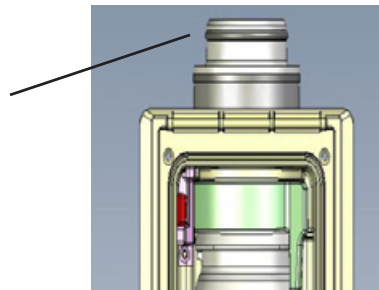

Using wire nuts connect the two leads from the switch that is mounted on the outside of the valve to the low voltage wire.

Insert the valve assembly into the rough in frame.

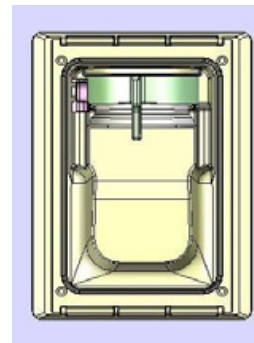
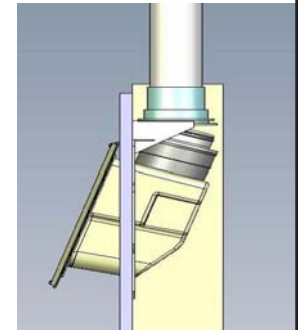

Align the four holes in the valve assembly with the holes in frame. Secure with the four screws included with the trim kit.

Install the door by lining up the door and valve hinge and pressing it into place.

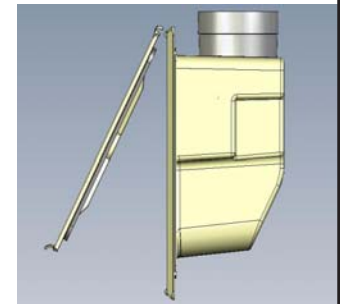

## Retro fit an existing home

Use the mud cover as a template to cut the hole.

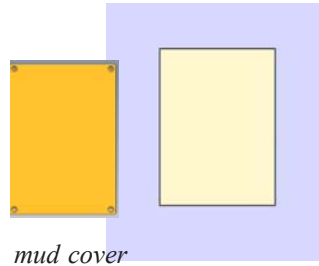

Insert the Rough In frame vertically, then turn it back upright behind the wall.

Depending on how close you are to a stud, you may need to score and cut off one or both of the mounting tabs.

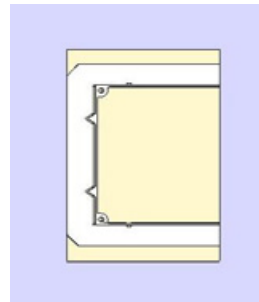

Push the bottom two pointed tabs into the sheetrock. The top pointed tab can be bent down as you pull the top of the frame into the hole. The tabs will help hold the frame into place while you install the valve. You may need to push a couple of small finish nails horizontally into the holes located on the side of the frame.

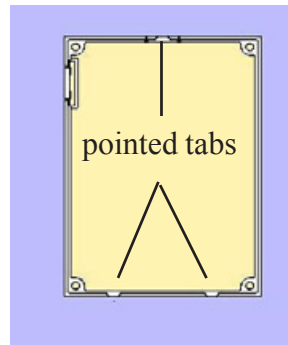

Follow the same instructions for installing the pipe runs and trim.